

# 팬 히터 Fan Heater

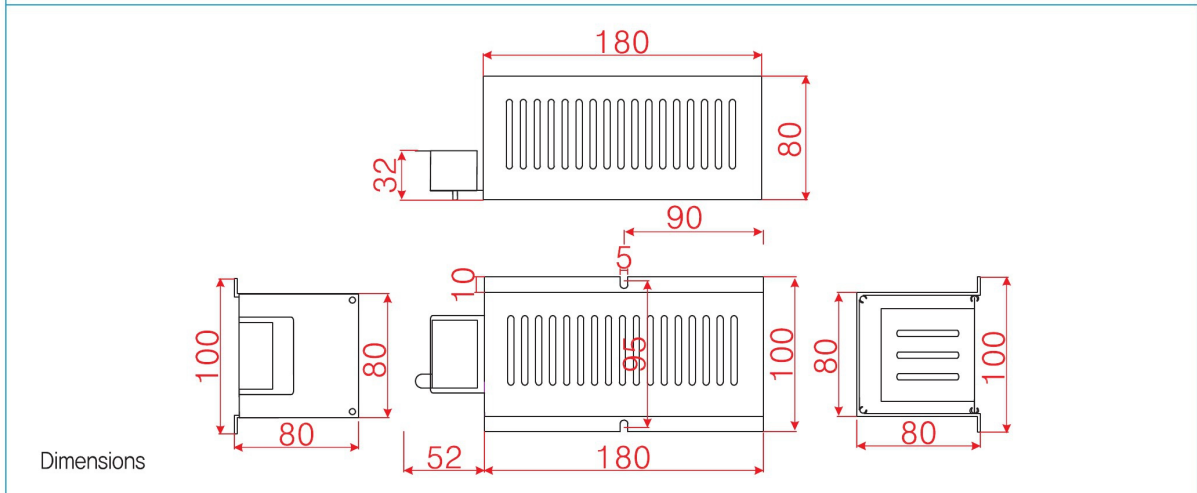
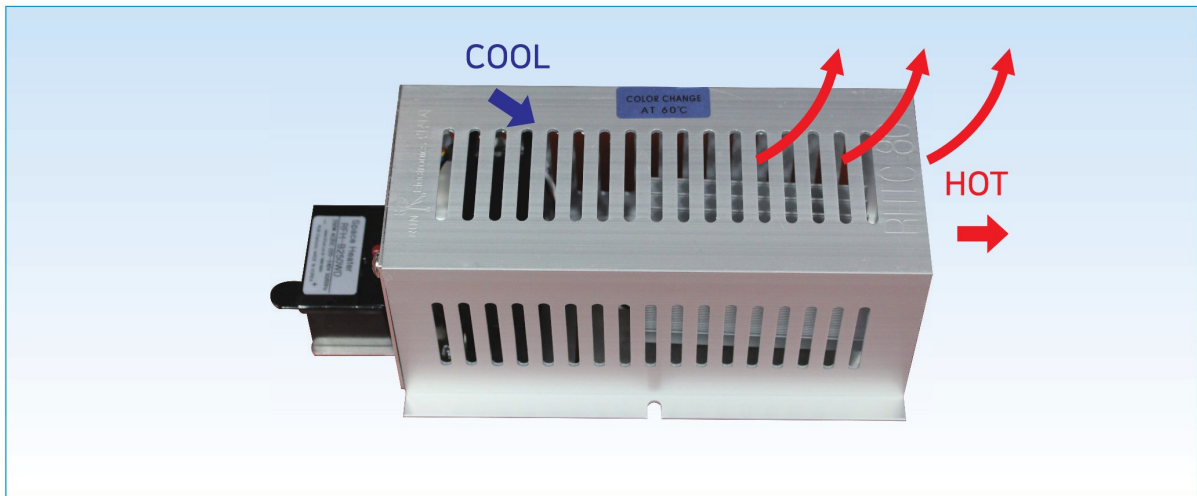

## 특징 (Characteristic)

1. ATM기, 지하철 게이트, 키오스크, 교통신호제 배전함, 자동제어함, 옥외 판넬, 계란 부화기, 활 보관함, 곤충사육함 등...
2. 과열 방지 바디메탈 부착

MODEL	전력 WATT	전압 Voltage	주파수 Hz	가로 Width	세로 Length	높이 Height	고정홀 Attachment hole	중량 Weight
RFH-B260WD	260W	AC220V~AC240V	50/60Hz	232	100	80	90×95	490g
RFH-B400WD	400W	AC220V~AC240V	50/60Hz	232	100	80	90×95	618g

재질 Materials			단자볼트 Terminal bolt	고정볼트 Attachment bolt	압착단자 Terminal lug	인증 Certification
몸체 Body	단자대 Terminal	단자카바 Terminal cap				
알루미늄 Aluminum	열경화성 페놀수지 Thermosetting phenol resin	PC V-0 (polycarbonate)	SUS M4×8	M4×10	1.5-4Y	KC

※ 중대한 주변기기의 손상 및 막대한 재산 피해가 우려되는 기기등에 사용할 경우에는 **이중으로 안전장치를 부착하여 사용하세요.**  
In case of using for machinery concerning injury and tremendous property damage of heavy, peripheral accessories attach & use safety device over again.